



Ingegneria delle Telecomunicazioni

Satellite Communications

8. Let it Snow– Atmospheric Impairments

Marco Luise

marco.luise@unipi.it

Dip. Ingegneria dell'Informazione, Univ. Pisa, Italy

Atmospheric Phenomena

- **Absorption:** A reduction in the amplitude (field strength) of a radiowave caused by an irreversible conversion of energy from the radiowave to matter in the propagation path.
- **Scattering:** A process in which the energy of a radiowave is dispersed in direction due to interaction with inhomogeneities in the propagation medium.
- **Refraction:** A change in the direction of propagation of a radiowave resulting from the spatial variation of refractive index of the medium.
- **Diffraction:** A change in the direction of propagation of a radiowave resulting from the presence of an obstacle, a restricted aperture, or other object in the medium.
- **Multipath:** The propagation condition that results in a transmitted radiowave reaching the receiving antenna by two or more propagation paths. Multipath can result from refractive index irregularities in the troposphere or ionosphere, or from structural and terrain scattering on the Earth's surface.
- **Scintillation:** Rapid fluctuations of the amplitude and the phase of a radiowave caused by small-scale irregularities in the transmission path (or paths) with time.
- **Fading/Shadowing:** The variation of the amplitude (field strength) of a radiowave caused by changes in the transmission path (or paths) with time.

Origin of Propagation Impairments

- Major Effects coming from
 - the troposphere, extending from the ground to an altitude of 15 km
 - Major effects close to the ground
 - The ionosphere, situated between 70 and 1000 km
 - Major effect at 400km
- Strongly different on different frequency bands
- Not fully predictable

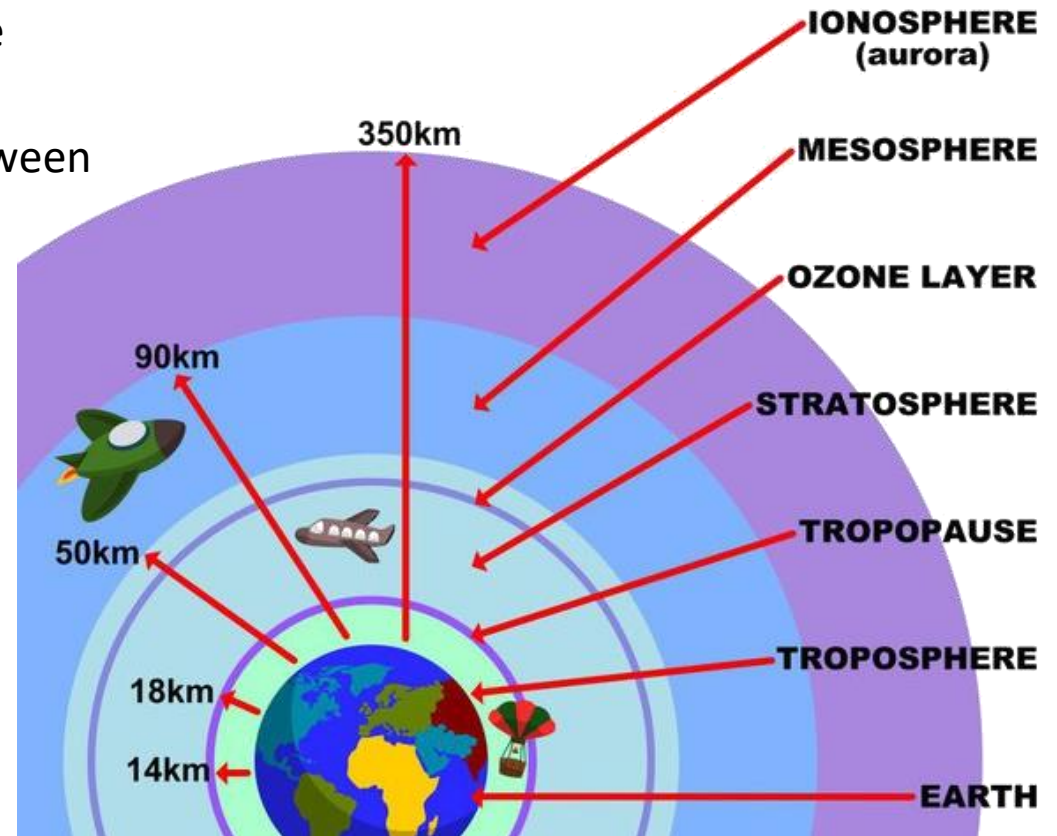

Atmospheric Attenuation

- **ITU-R gives recommendations about how to compute the atmospheric attenuation in link budget and system design, and provides map of (average) values for different regions of the world**
 - Atmospheric gases attenuation in dB (ITU-R P.676 Annex 2)
 - Rain attenuation in dB (ITU-R P.618)
 - Clouds attenuation in dB (ITU-R P. 840)
 - Scintillation in dB (ITU-R P.618-8)
- **The Recommendations rely on a set of publicly available data**
 - Rain intensity in dB (ITU digital maps)
 - Wet term of refraction co-index (ITU digital maps)
 - Rain height (ITU digital maps)
 - Total Columnar content (ITU digital maps)
 - Water vapor content (ITU digital maps)
 - Temperature (ITU digital maps)

Attenuation by Rain

- The attenuation is strongly dependent on the carrier frequency
 - It can be predicted via physical models as a function of the **rain rate r** in **mm/h** and of the **path l_e** traveled by the radio wave in the rain:

$$L_{rain} = \gamma_r l_e = a r^b l_e \text{ (dB)}$$

- γ_r (dB/km) depends on the rain rate as $\gamma_r = a r^b$ (a and b temperature- and frequency-dependent coefficients)
- l_e is the equivalent path length (km) in the rain, depending on the satellite elevation θ , the height of the rain zone h_r , etc.
(the formulas are too cumbersome)

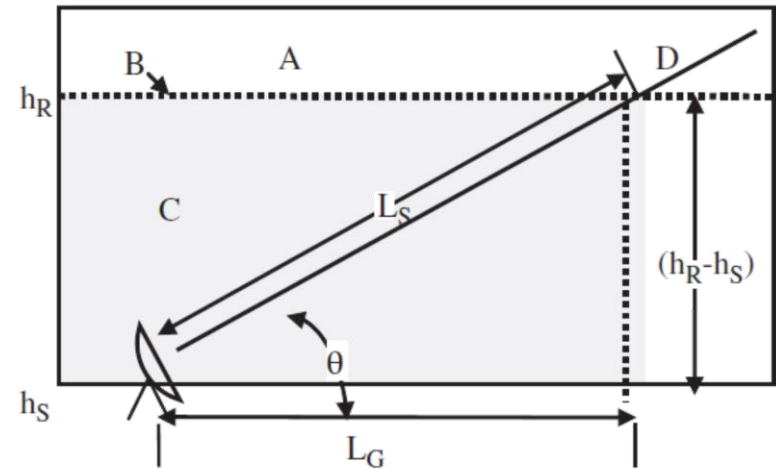

Example: overall values of γ_r

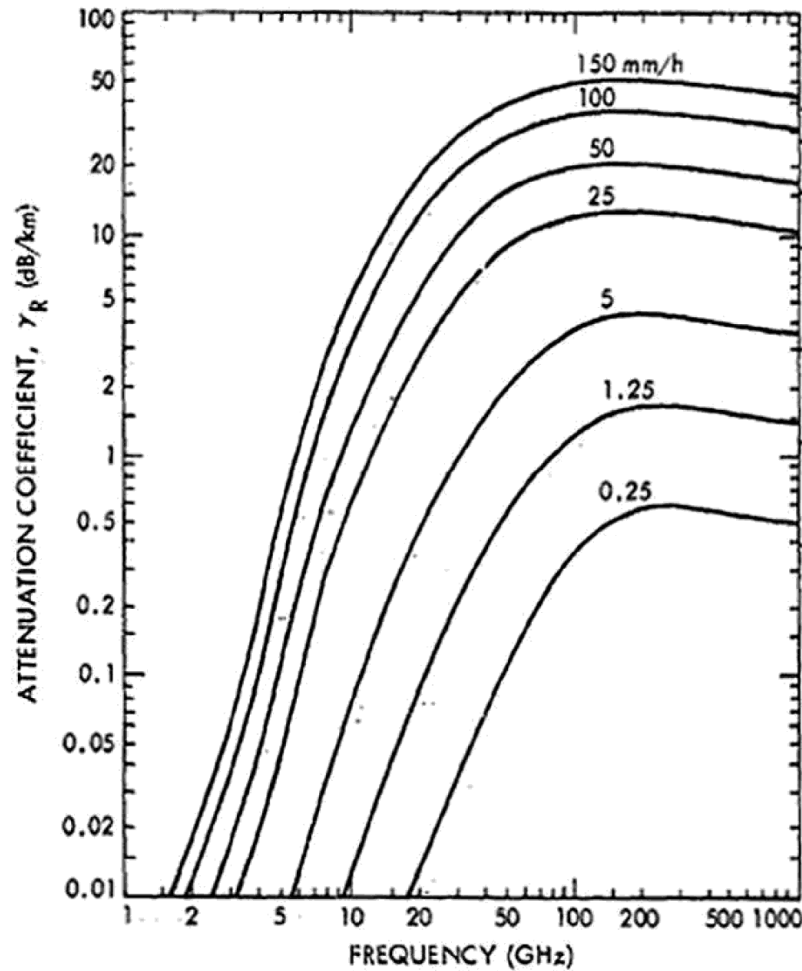

- As shown in this particular but typical case, the attenuation beyond Ka band is problematic
- Some form of countermeasures are needed (diversity) to increase availability of the link
- The relevance of the countermeasures strongly depend on the climatic zone (cdf of rain rate)
- Leads to an attenuation L_{rain} that is substantially negligible below 3 GHz

Rain Map

Rain intensity r (mm/h) exceeded for 0.01% of an average year – The corresponding attenuation

$$L_{rain} = a r^b I_e$$

becomes an additional margin in the link budget to secure 0.01% availability

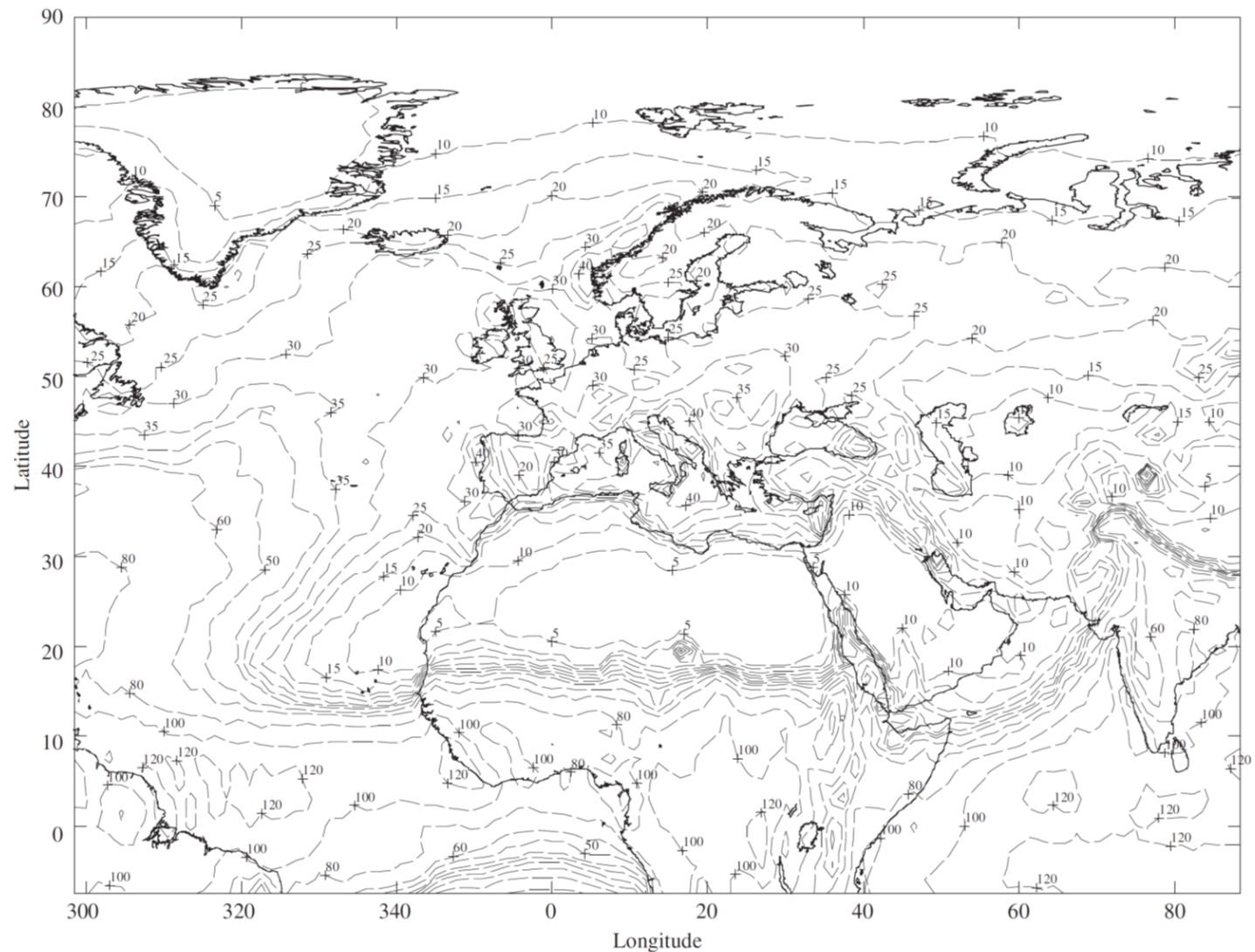

Washington, DC, 99% availability (i.e. worst 1% of the year)

In practice, a worst-case approach is taken: the value of r is taken as the worst-case $x\%$ of the (average) year to grant a $(100-x)\%$ availability of the link

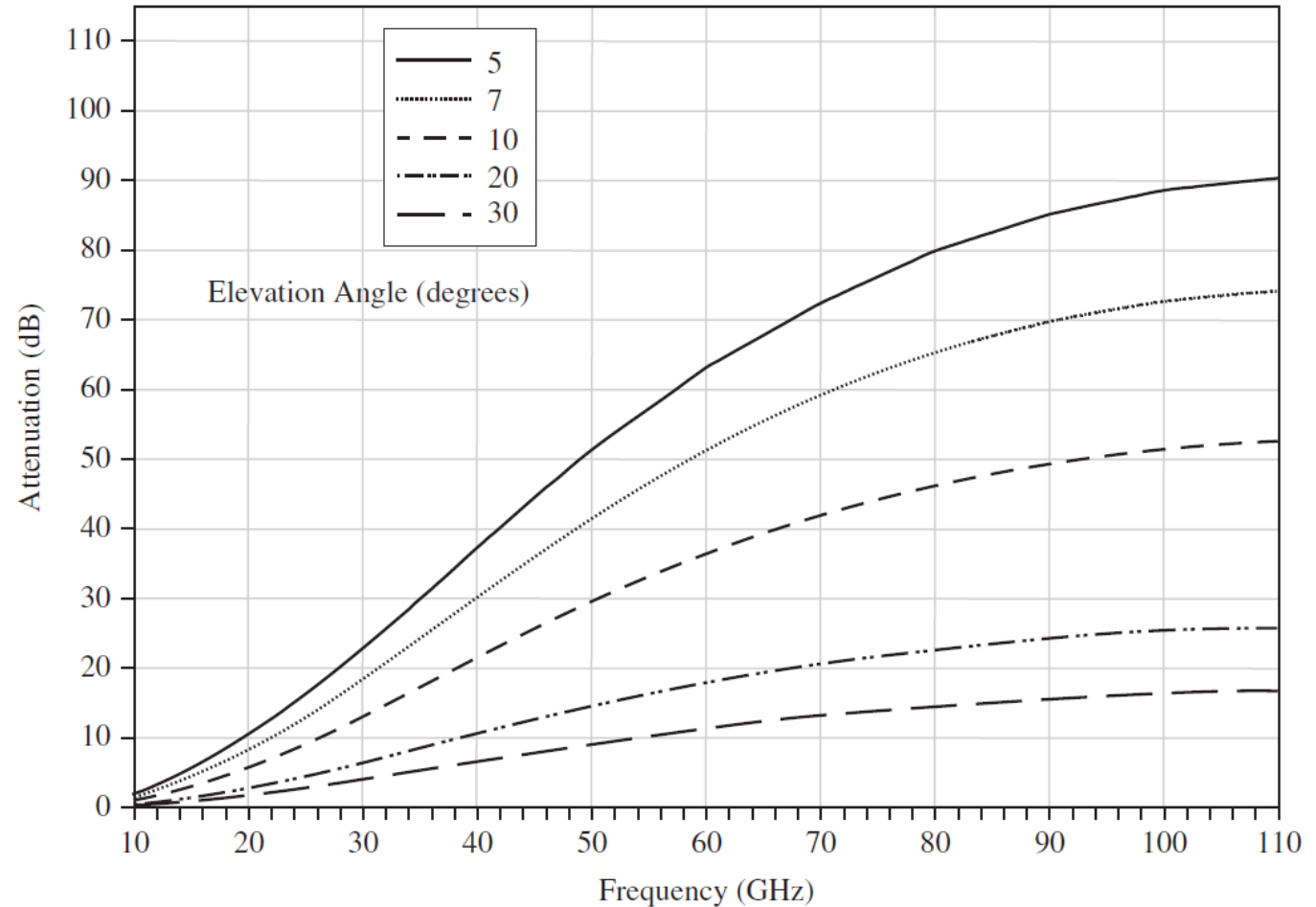

GW Site Diversity

- Idea: Re-routing the traffic to an Earth station which is experiencing less attenuation.
- Diversity gain calculated using empirical formulas specified in the ITU-R P.618 recommendation as a function of site distance d

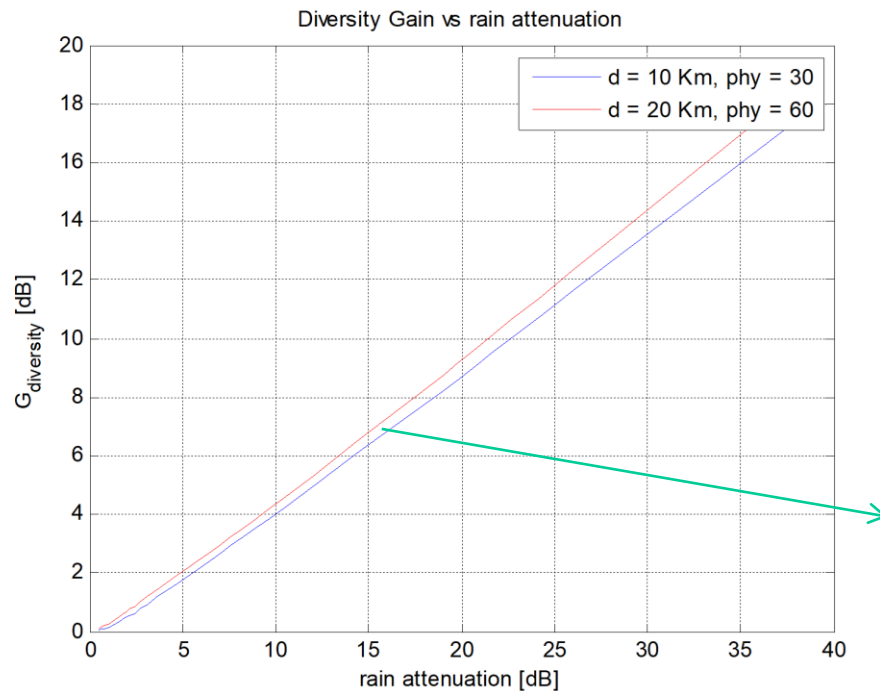
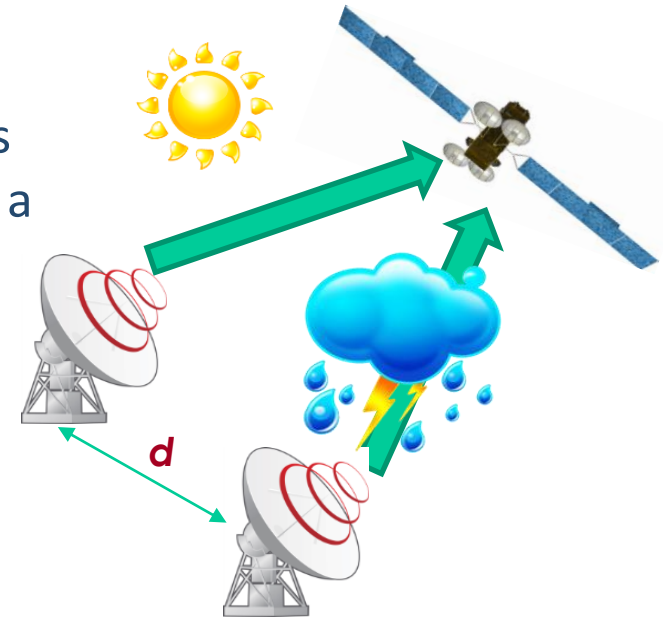

Gateway with an elevation angle of 30 degrees suffers 15 dB of attenuation for a given availability.

When there is a second gateway separated by 10 km, for the same availability, there will be 6.2 dB reduction in the attenuation.

It's not over: *Depolarization* caused by rain

- It is produced from a differential attenuation and phase shift caused by non-spherical, possibly inclined (due to wind) raindrops
 - Particularly relevant when polarization diversity is used to increase spectral efficiency

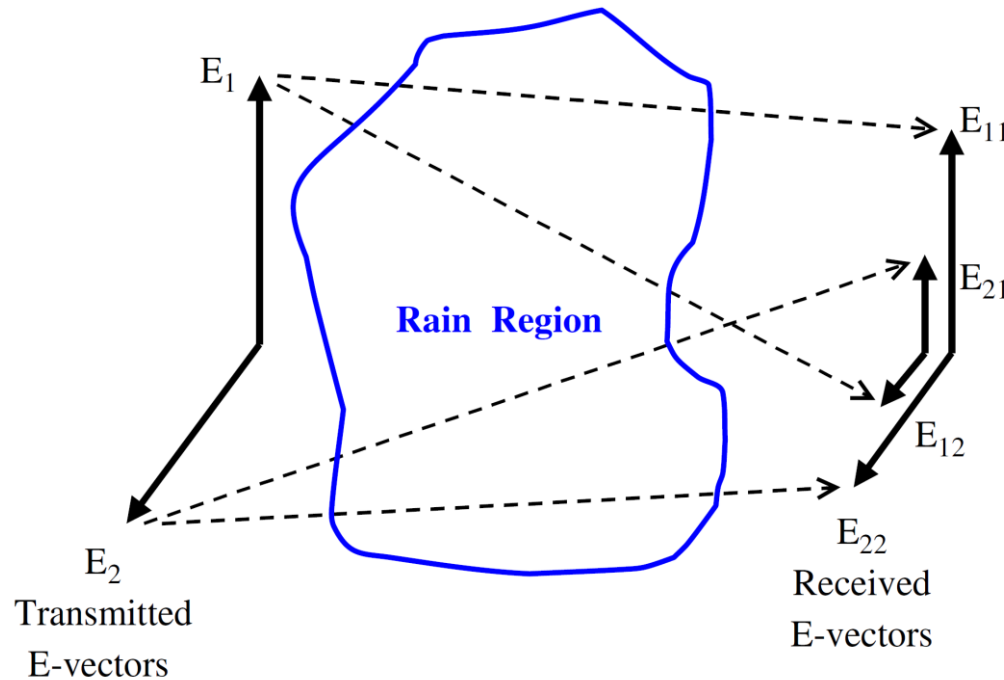

$$I_1 \triangleq 10 \log \left(\frac{|E_{11}|^2}{|E_{21}|^2} \right)$$

$$I_2 \triangleq 10 \log \left(\frac{|E_{22}|^2}{|E_{12}|^2} \right)$$

Characterization of Depolarization

In general, negligible for “reasonable” frequencies and “reasonable” elevation angles

Circular polarization can be considered equivalent to 45-degree linear

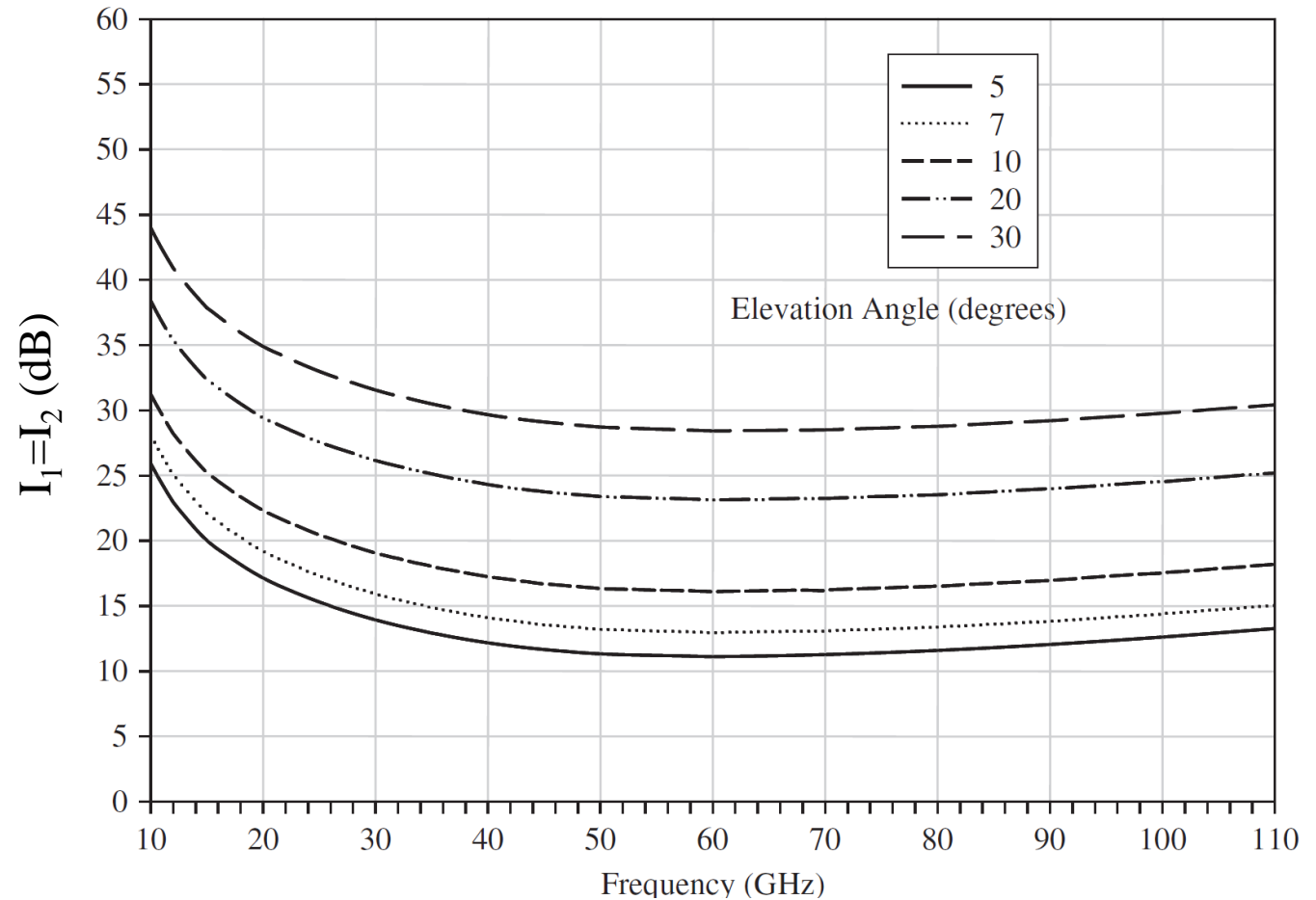

Gaseous Absorption, ITU-R P.676

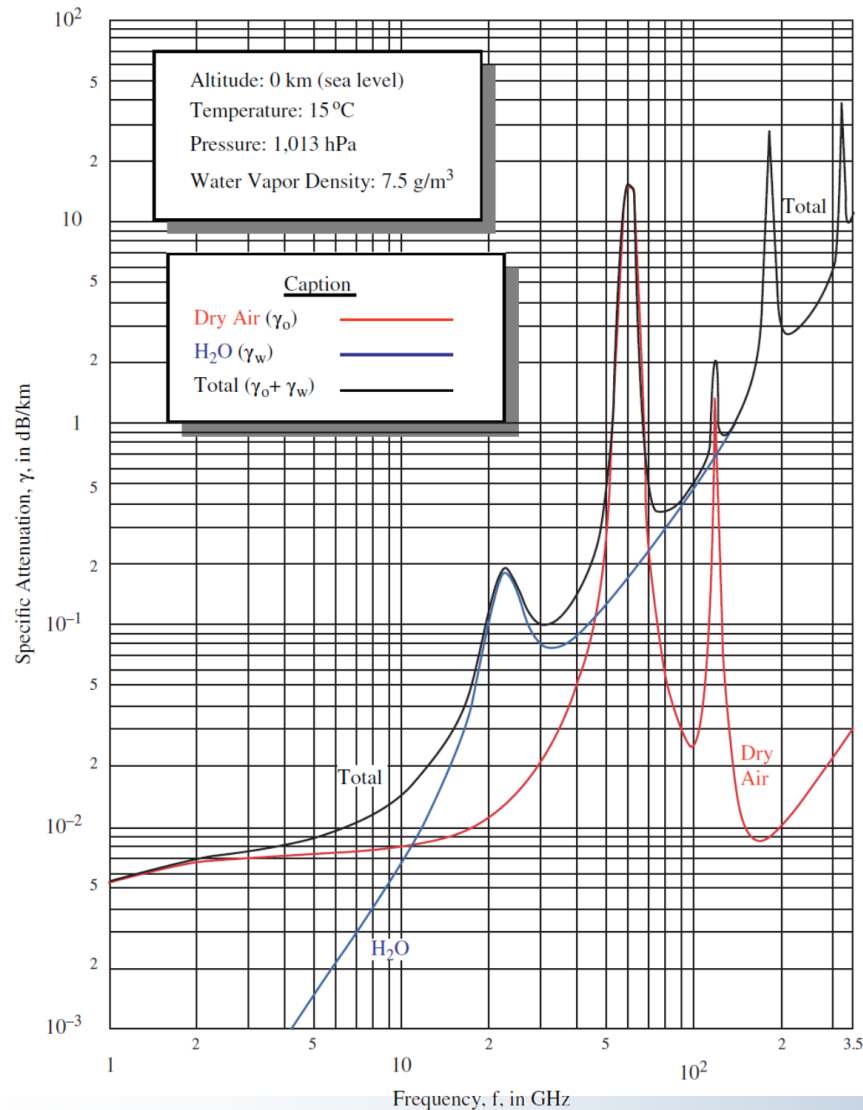

- Different Gas Components of the atmosphere give different unit attenuation coefficients (dB/km)
- Notice the notorious absorption peak @ 60 GHz

Gaseous Absorption, ITU-R P.676

- The total attenuation is computed according to the path traveled into the atmosphere (depending on the elevation θ)
- In practice, we take the Zenith attenuation/ $\sin(\theta)$
 - Again, negligible for “low” frequencies, considerable for Q band (33-50 GHz) or V band (40-75 GHz)

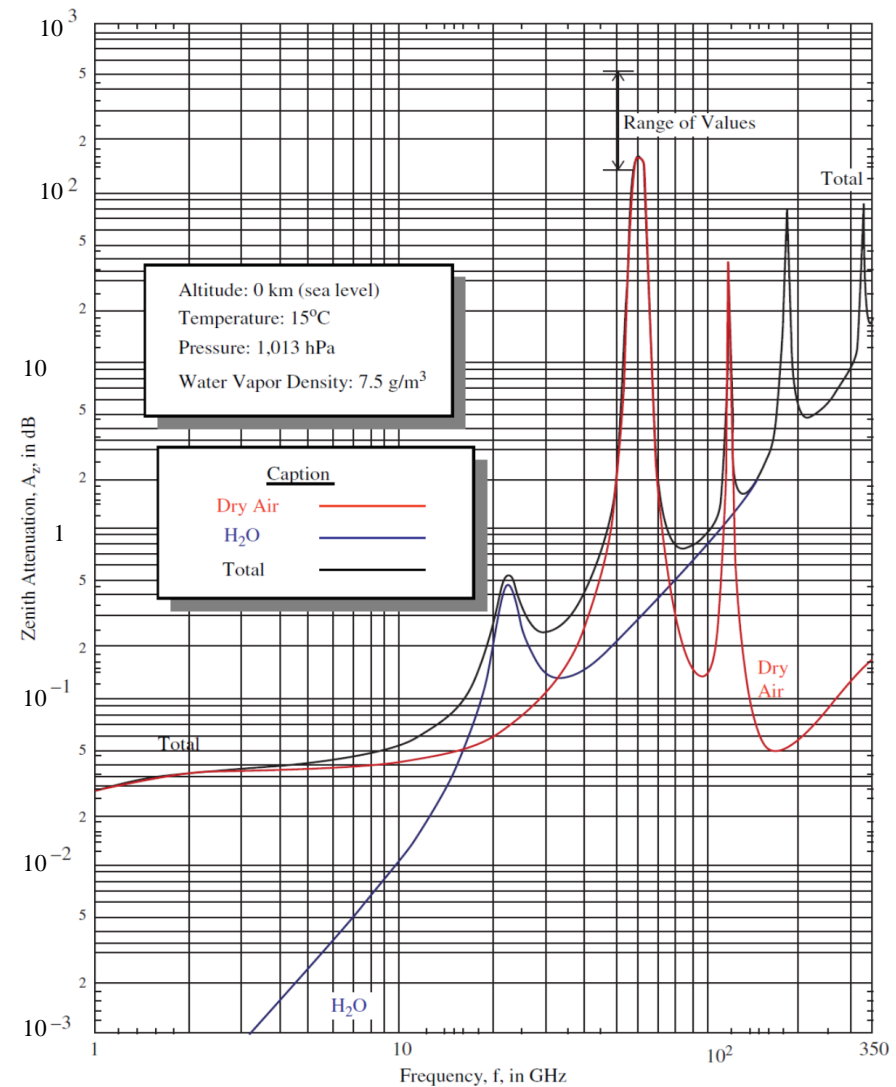

- **Fog**
 - Is made of water *droplets*, not water vapor
 - Attenuation negligible at all frequencies < 100 GHz
- **Clouds**
 - Water droplets again, not water vapor
 - Are characterized by water content (g/m^3). The total attenuation is the product of unit attenuation ($\text{dB}/(\text{g}/\text{m}^3)$) times the total content of the “water column” above the Earth station (kg/m^2), divided of course by $\sin(\theta)$ (elevation angle)
 - The result is a substantially smaller attenuation than for rain, but in general on longer time periods.

Attenuation significant only beyond Ku-band

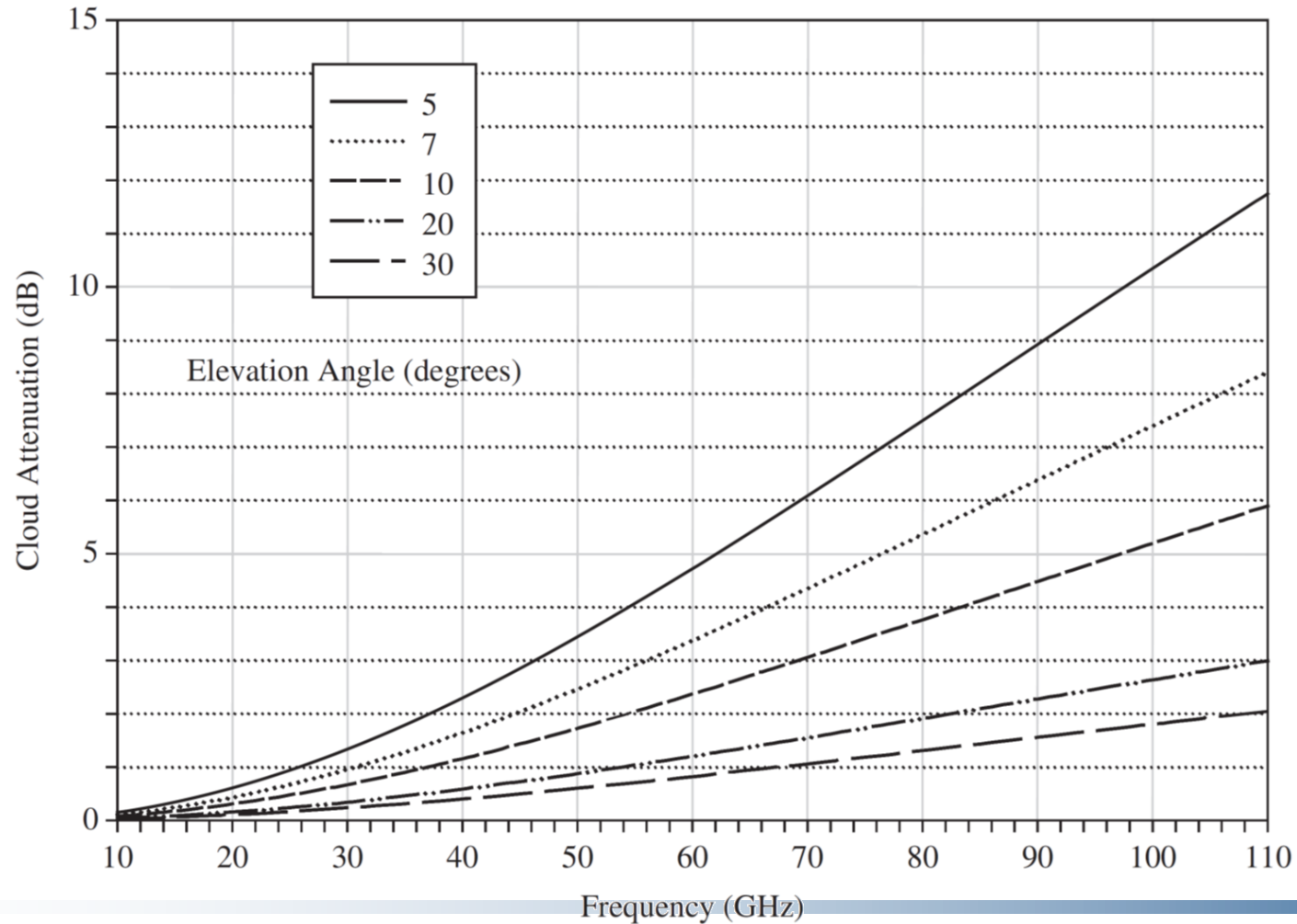

The Ionosphere: Plasma gas

- The ionosphere is a region of ionized gas or plasma that extends from about 15 km to more than 400 km altitude.
- It is ionized by solar radiation in the ultraviolet and x-ray frequency range and contains *free electrons and positive ions* (actually, less than $< 1\%$ molecules, mainly oxygen and nitrogen, are ionized)
- The free electrons affect electromagnetic wave propagation for satellite communications – it is not just propagation in the vacuum any longer
- The effect is weak, but not negligible
- The main property of the ionosphere that affects propagation is the *electron concentration* as a function of the altitude

Ionospheric Electron Concentration

Daytime

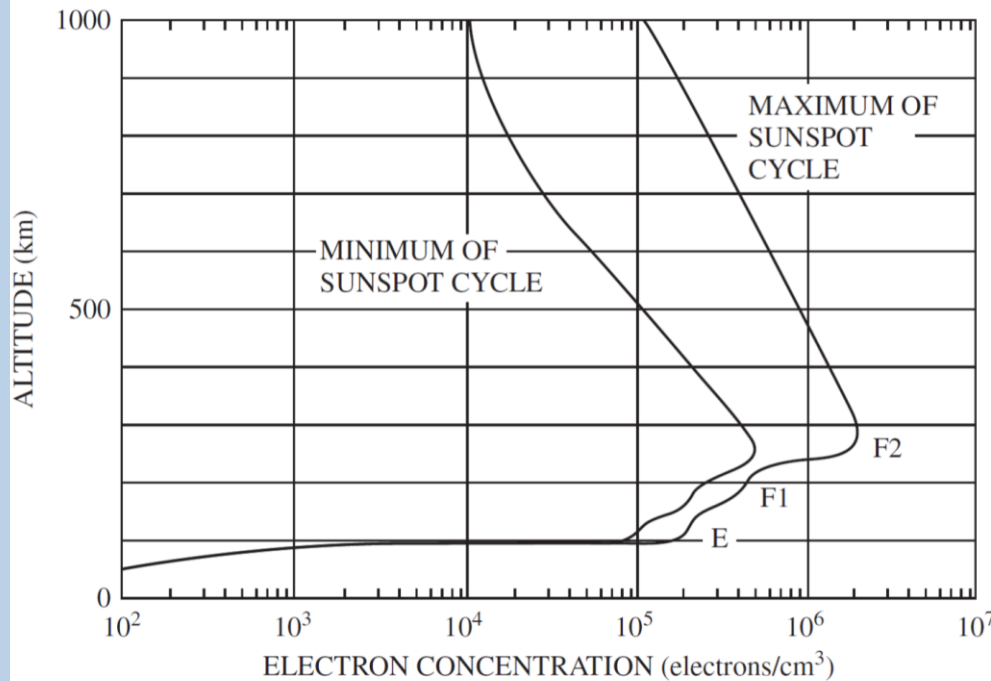

Nighttime

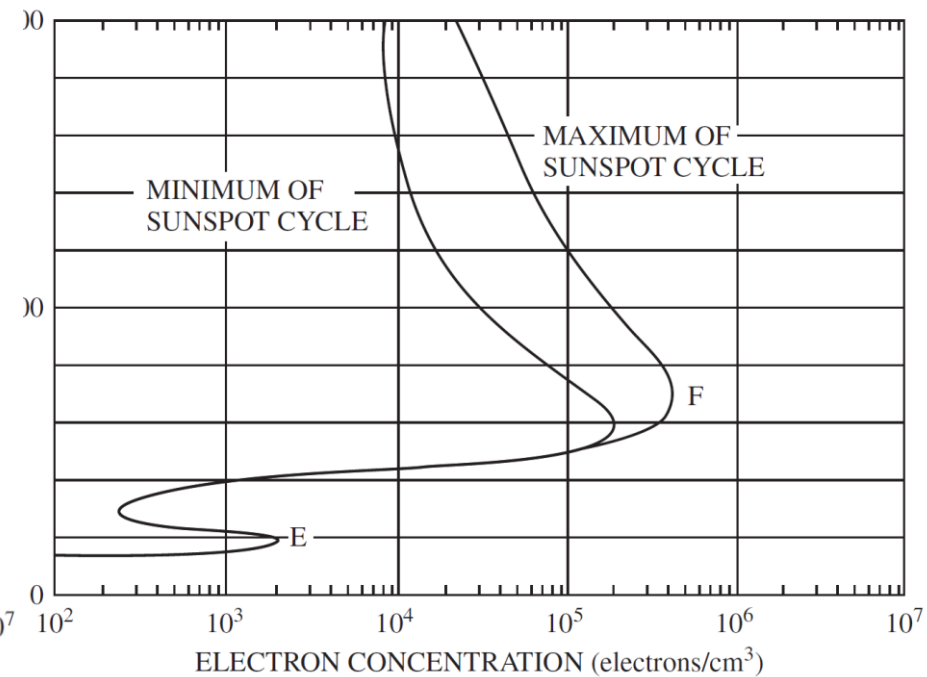

The main effects of this is i) *Scintillation*, and ii) *Additional propagation delay*

Ionospheric Scintillation

- Rapid fluctuations of the amplitude and phase of the radiowave, caused by electron density irregularities in the ionosphere
- Strongest at UHF (30-300 MHz), strikes up to 7 GHz
- Is a source of fading/shadowing on the received signals - can be modeled with a Rayleigh/Nakgami distribution with Doppler spread 0.1-1 Hz and duration (up to) 30 minutes

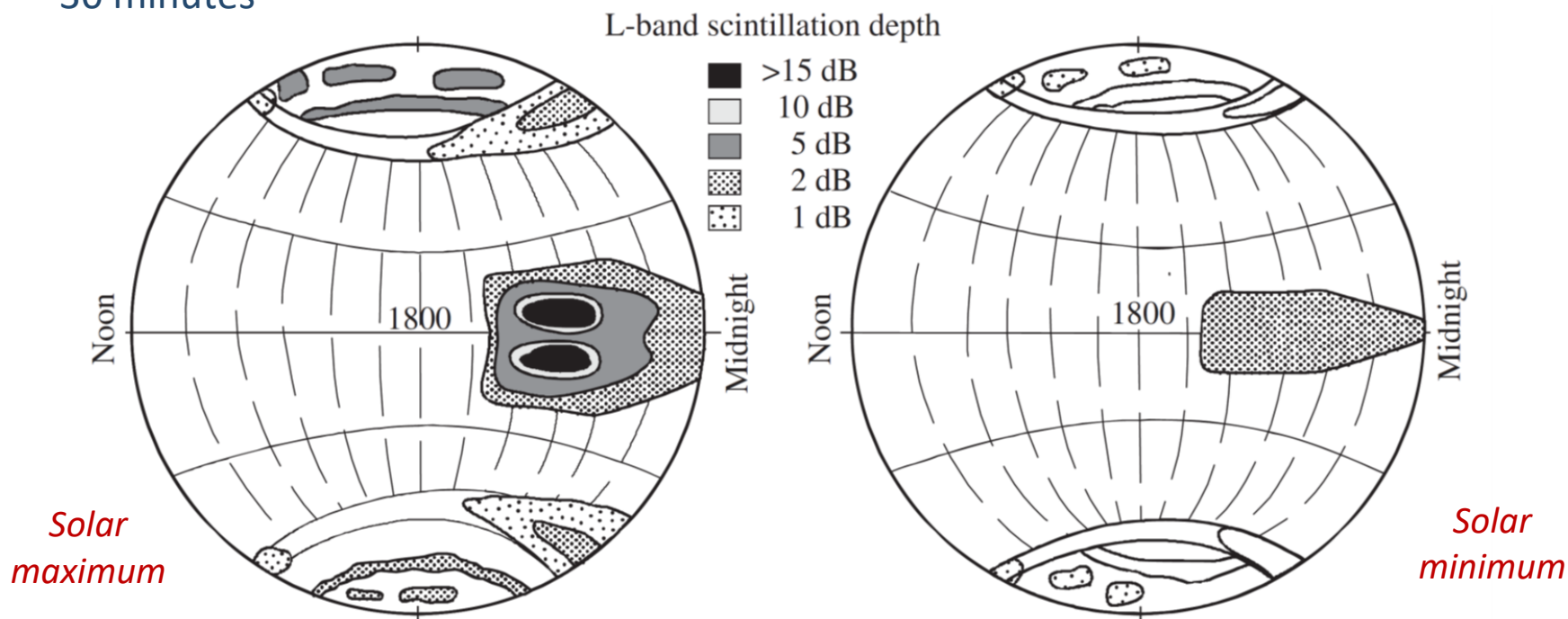

(Additional) Ionospheric Group Delay

- The presence of electrons increases the refraction index of the ionosphere so that the wave is *retarded* wrt propagation in the vacuum (thicker medium...)
- In terrestrial radio communication, this effect can be used to *bend* the path of the wave that “bounces back” on the ionosphere and propagate well beyond the horizon – this was used for long time in the HF band to realize intercontinental radio communications
- In GNSS, the distance from the satellite to the receiver (the *range*) r is evaluated by measuring the “flight time” τ of the radio signal from the satellite to the user receiver as $r = c\tau$, i.e., assuming propagation in the vacuum. If the ionosphere introduces an additional (unknown) delay, then the measurement is *biased* and not accurate, and the positioning will result not accurate as well
- THEREFORE, especially for GNSS (and we are anticipating topics we will deal with later on in the course), we need to be able to estimate and possibly correct the ionospheric delay: ionospheric bulletins (Space Weather Centers) !

Computation of the Ionospheric Delay

- The refraction index of the ionosphere depends on the frequency f of the wave, and on the *local electron content* $n_e(\mathbf{r})$, where \mathbf{r} is a generic point along the wave propagation path. The expression is found to be (n_e in electrons/cm³ and f in Hz).

$$n(\mathbf{r}) = 1 + \frac{40.3 n_e(\mathbf{r})}{f^2}$$

- The flight time from the satellite to the Earth is

$$\tau = \int_{SAT}^{EARTH} \frac{ds}{v(\mathbf{r})} = \frac{1}{c} \int_{SAT}^{EARTH} n(\mathbf{r}) ds = \frac{1}{c} \int_{SAT}^{EARTH} \left(1 + \frac{40.3 n_e(\mathbf{r})}{f^2} \right) ds = \frac{r}{c} + \frac{40.3}{f^2} \frac{1}{c} \int_{SAT}^{EARTH} n_e(\mathbf{r}) ds$$

- We see that r/c is the vacuum-propagation delay, so that the ionospheric (additional) delay τ_{iono} is...

$$\tau_{iono} = \frac{40.3}{f^2} \frac{1}{c} \int_{SAT}^{EARTH} n_e(\mathbf{r}) ds = \frac{40.3}{c \cdot f^2} N_T$$

$$\tau_{iono} = \frac{40.3}{c \cdot f^2} N_T$$

- N_T is the Total Electron Count (TEC) along the radio path and it is the parameter that actually determines how large the iono delay is.
- The equation is also formulated as

$$\tau_{iono} = \frac{1.345}{f^2} N_T \cdot 10^{-25}$$

- with N_T expressed now in electrons /m² and frequency in GHz.
- Usual values of TEC are 10¹⁶ - 10¹⁸ /m²

Mean Values of VTEC (Vertical N_T) across the Years

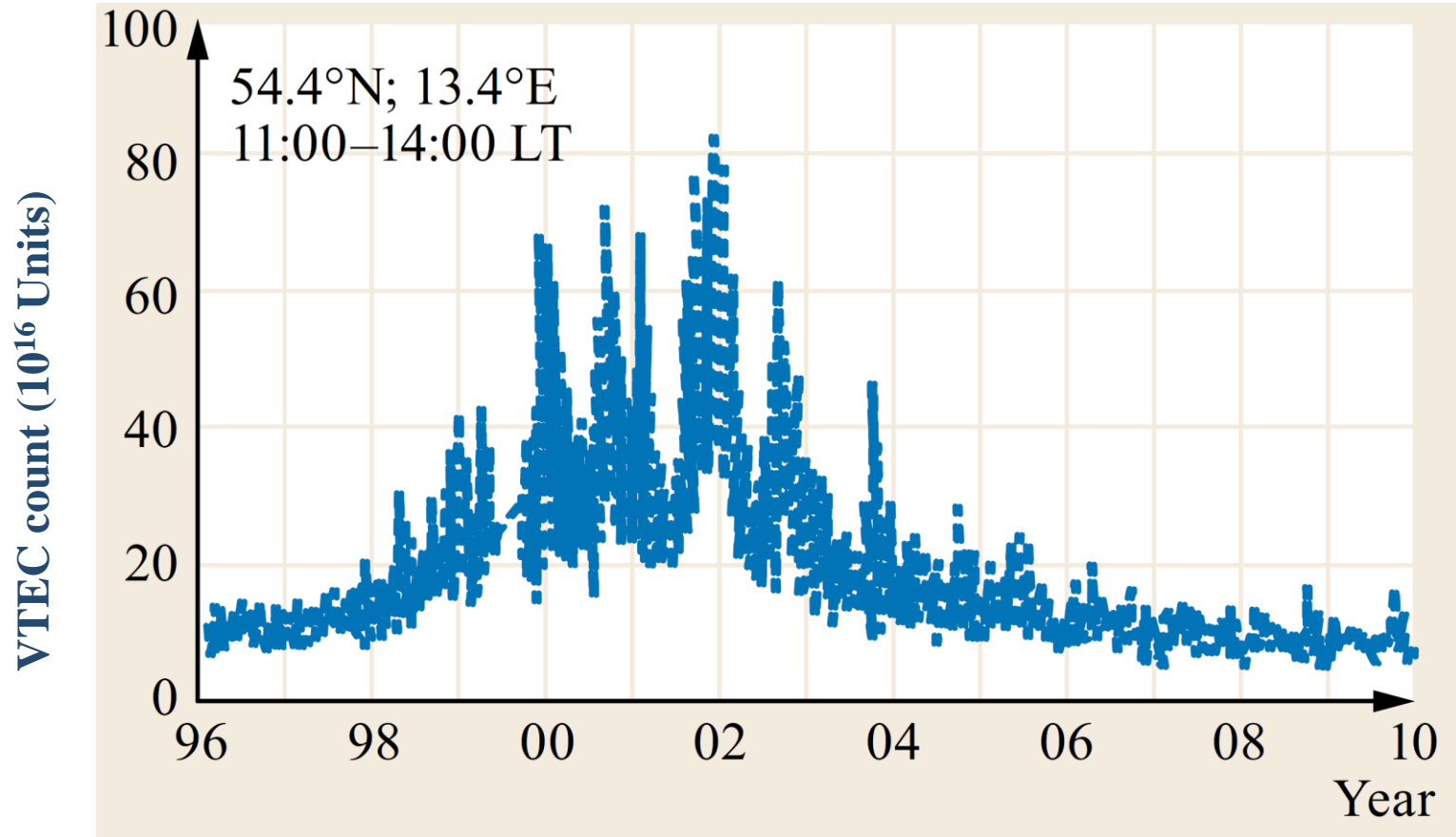

Iono Delay Chart

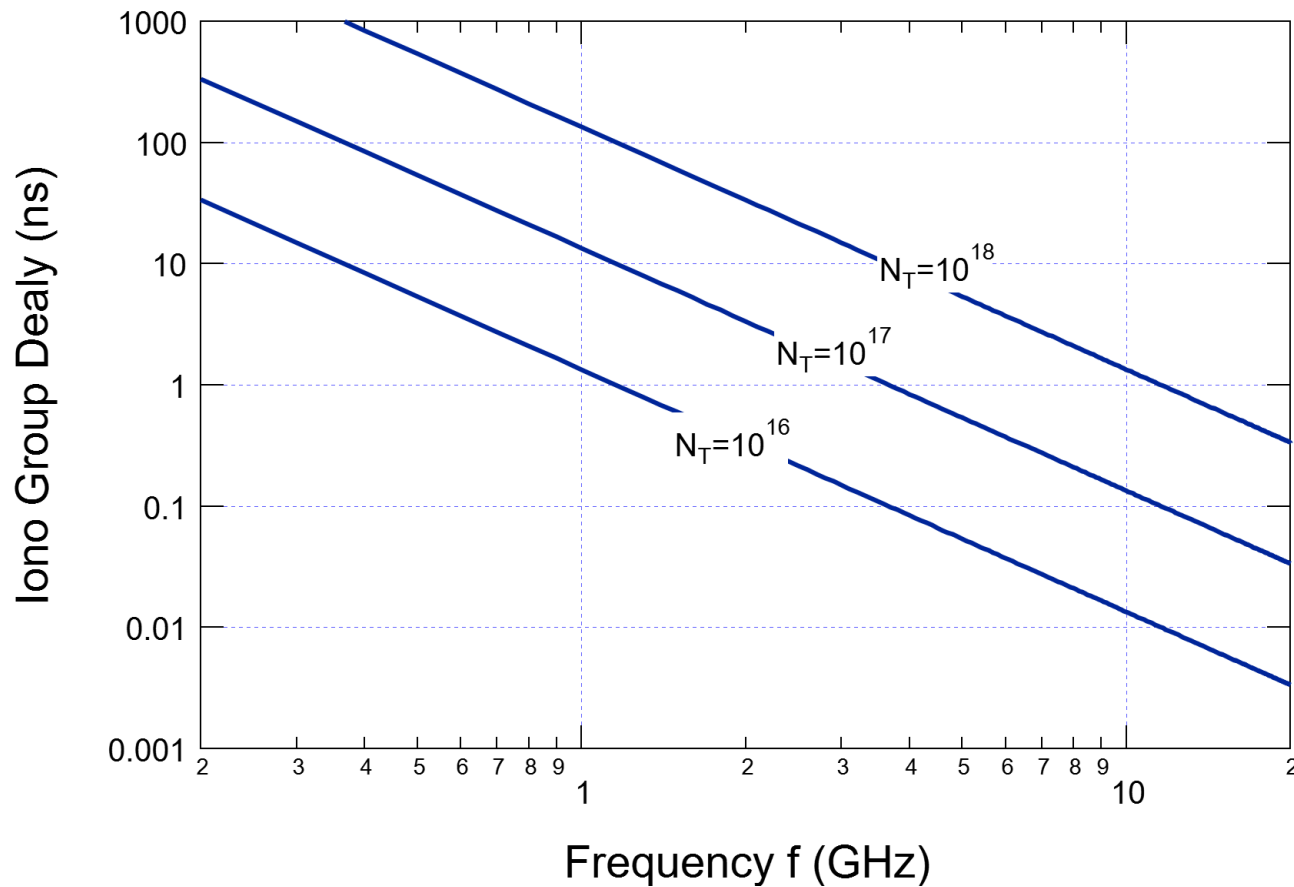

- The nominal delay for a GALILEO satellite @ 24,000 km altitude is 80 ms – this delay (smaller than 1 μ s) may appear negligible but...

Iono Range Bias

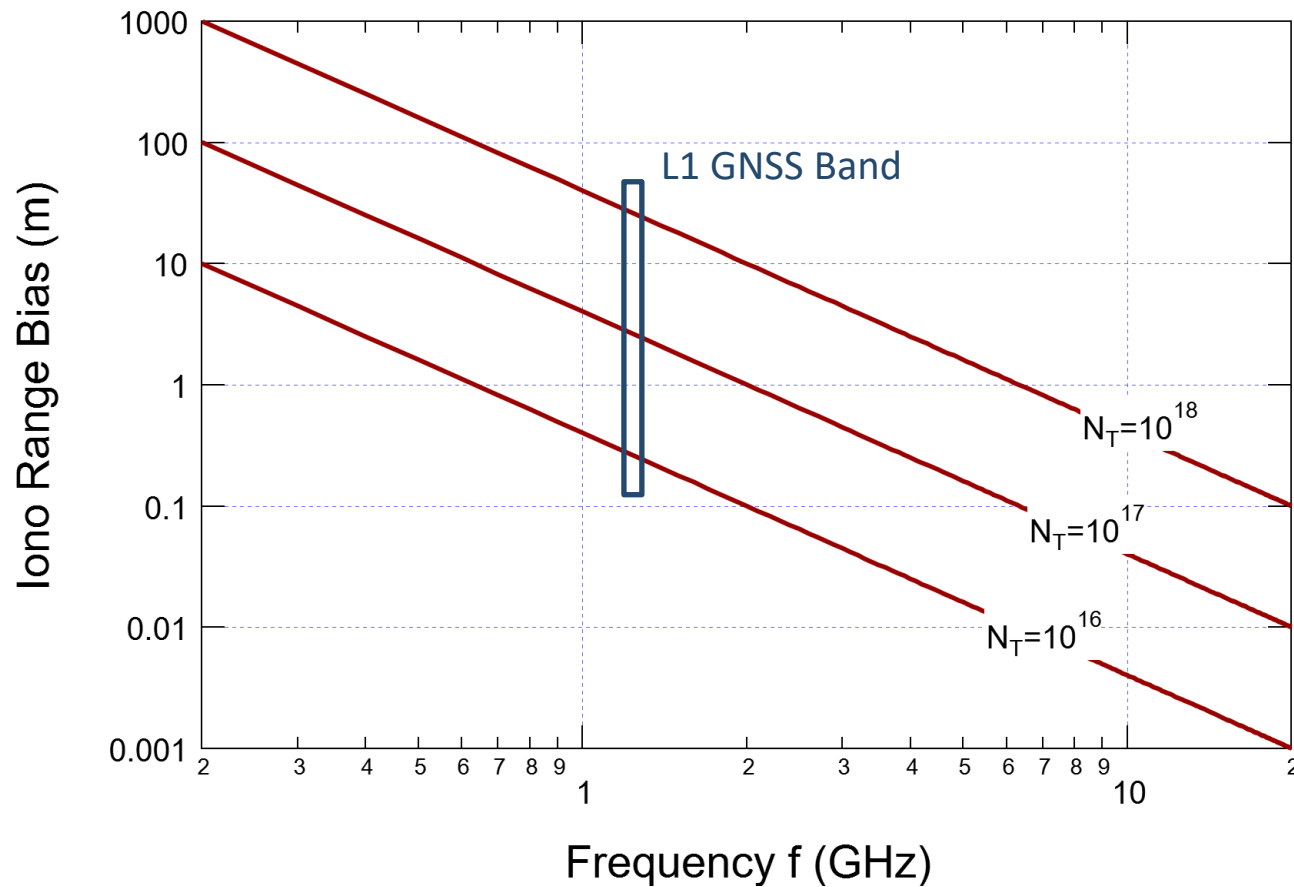

- It actually represent a *bias* in the sat-to-Earth range with values above – not negligible at all if we whis to get to an accuracy of about 1 m !!!

We can now get back to Link Budget with impairments...

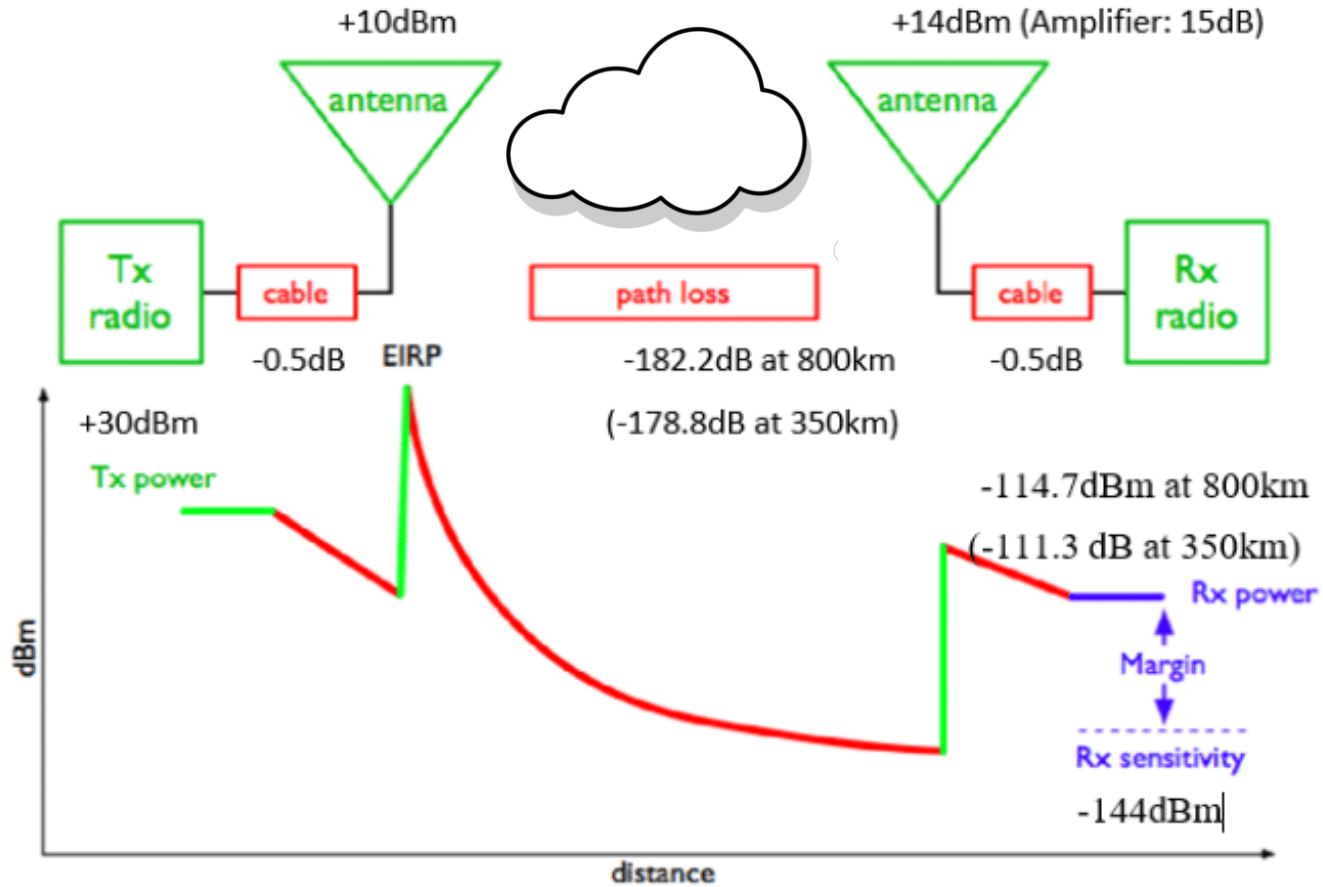

Adverse Propagation Conditions

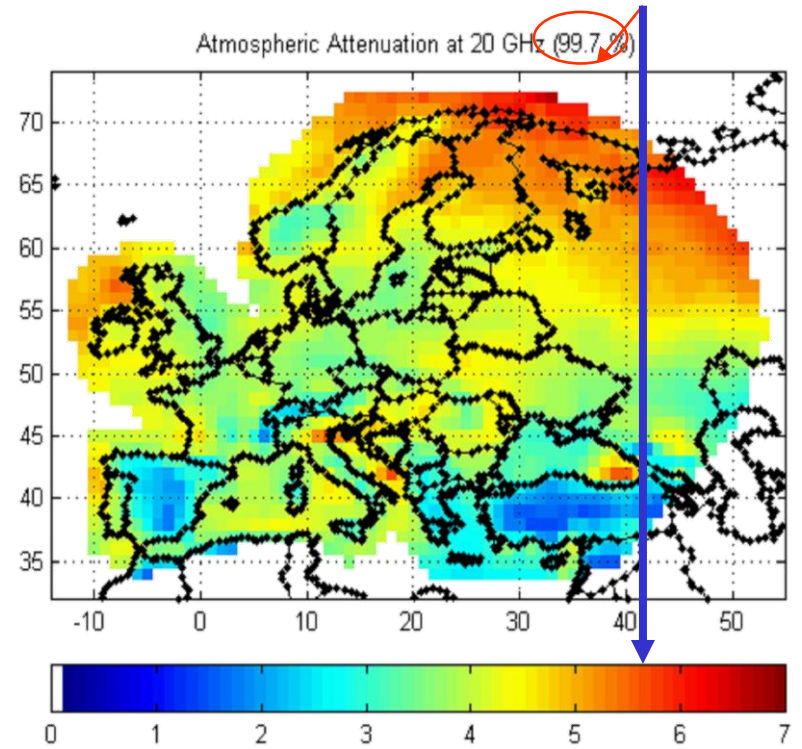
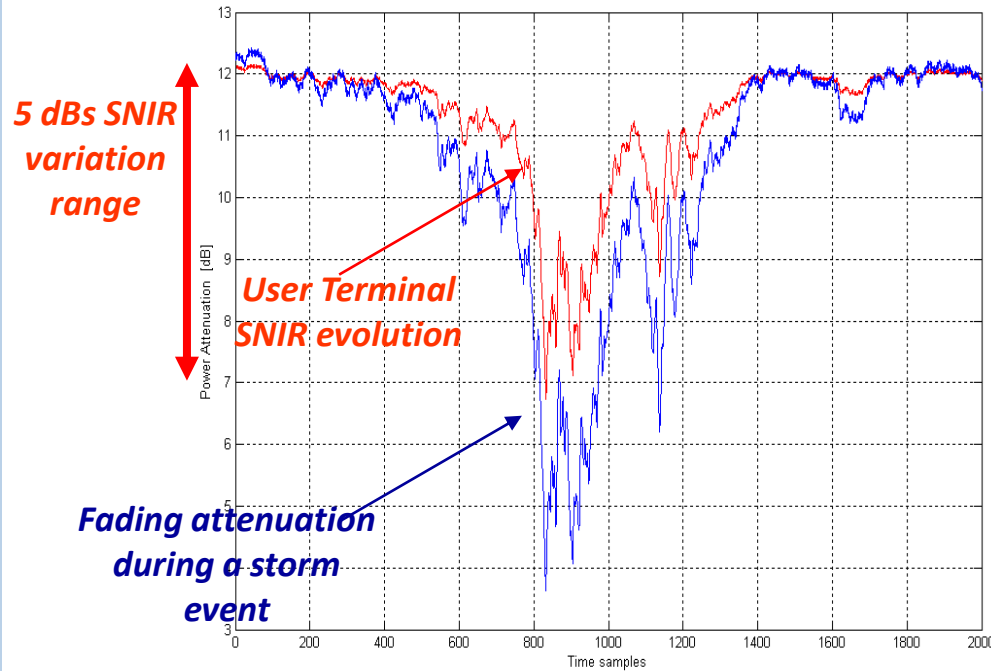

Adaptive/Variable Coding and Modulation (ACM/VCM)

